

JOB NAME:

QUANTITY:

ITEM NO.:

SPEC. 32840

PRODUCT NAME:

SPRAY GUN

_____ SPECIAL CONFIGURATION
(CHECK BASE MODEL AND OPTIONS)

MODEL:

32840 SPRAY GUN

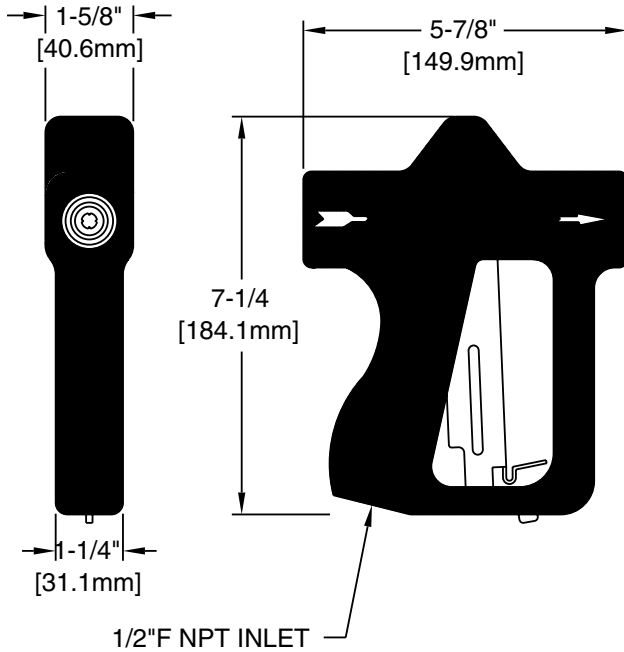

FEATURES

- * 1/2" FEMALE NPT INLET
- * STAINLESS STEEL CONSTRUCTION
- * WATERPROOF NYLON COVER
- * ERGONOMIC DESIGN
- * LOCKING TRIGGER MECHANISM

SYSTEM LIMITS

- * TEMP: 40°F MIN. TO 140°F MAX.
- * PRESSURE 150 PSI MAX. STATIC
- * 7.0 GPM AT 80 PSI

SHIPPING WEIGHT

- * 2.0 LBS

ANSI/A112.18.1M